



Fagor Automation S. Coop.

Manual code: 14460166

Manual version: 1405



ENCODER HAD-D90

MANUAL DE INSTALACIÓN
INSTALLATION MANUAL

FAGOR AUTOMATION S. COOP.

B^a San Andrés N^o 19

Apdo de correos 144

20500 Arrasate/Mondragón

- Spain -

Web: www.fagorautomation.com

Email: info@fagorautomation.es

Tel.: (34) 943 719200

Fax: (34) 943 791712



Fagor Automation S. Coop.



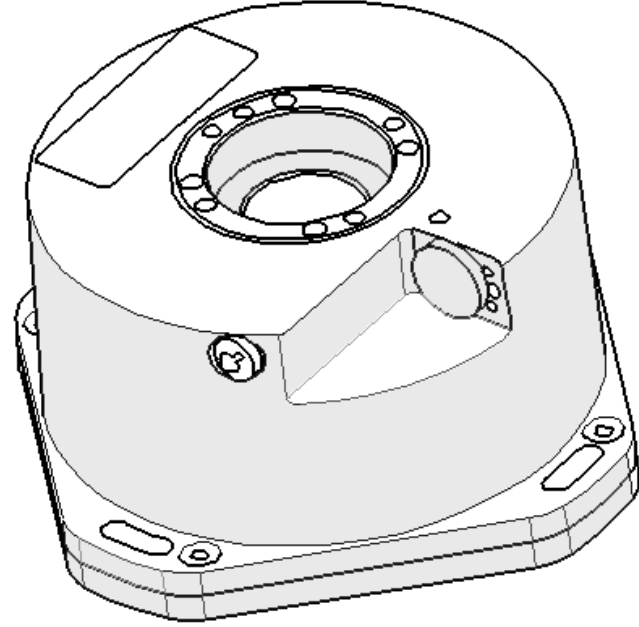

MANUAL



GRÁFICO
GRAPH



ACCESORIOS
ACCESSORIES

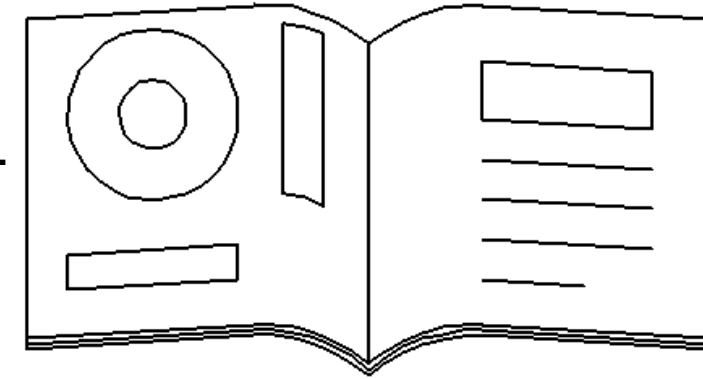
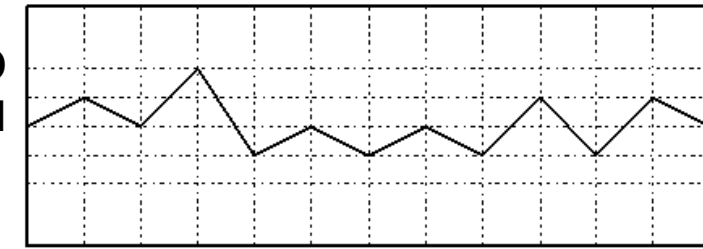
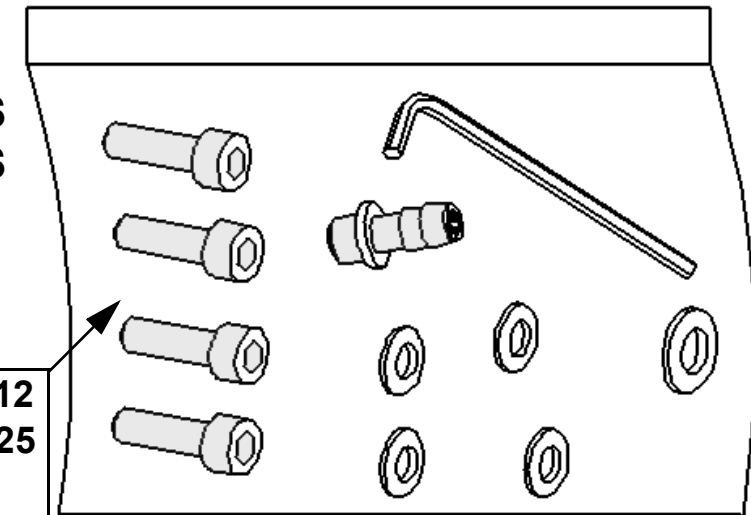

4 tornillos/bolts M4 x 16 DIN 912
4 arandelas/washers M4 DIN 125
1 racor de aire / air intake
1 arandela racor de aire /
air intake washer
1 llave Allen / Allen wrench



DIN EN 100

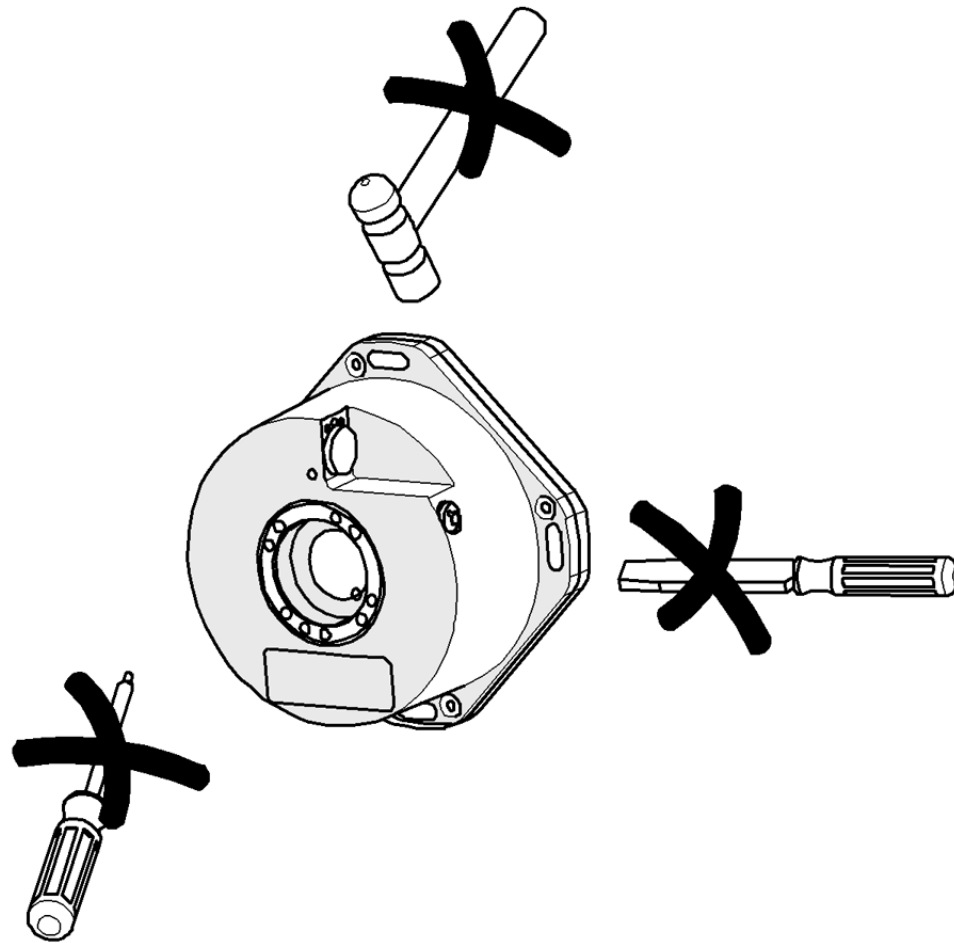
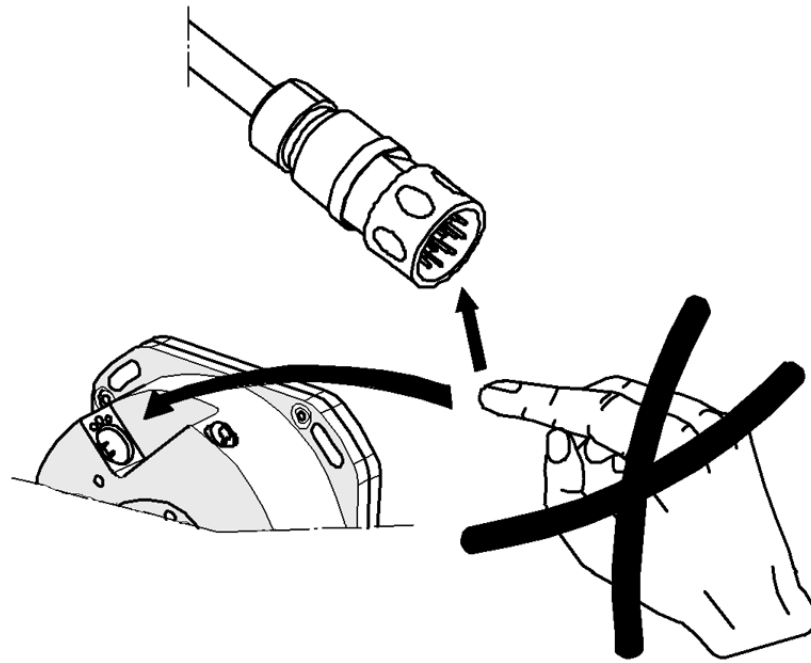
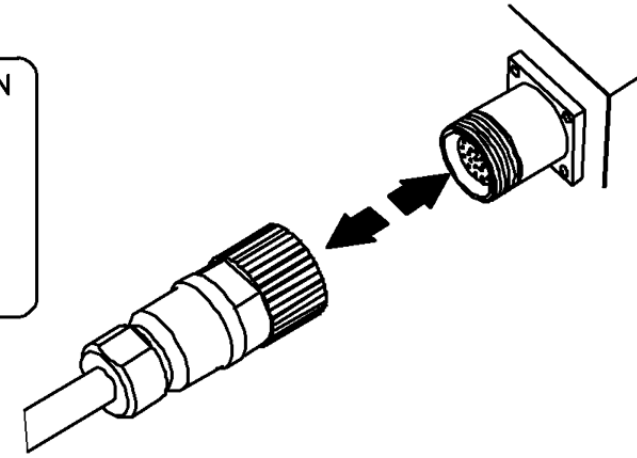
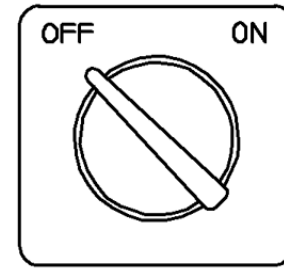
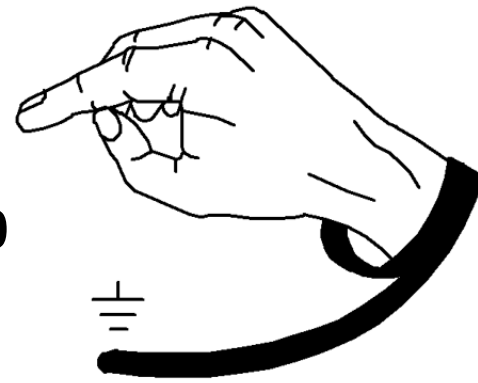

GENERAL DIMENSIONS

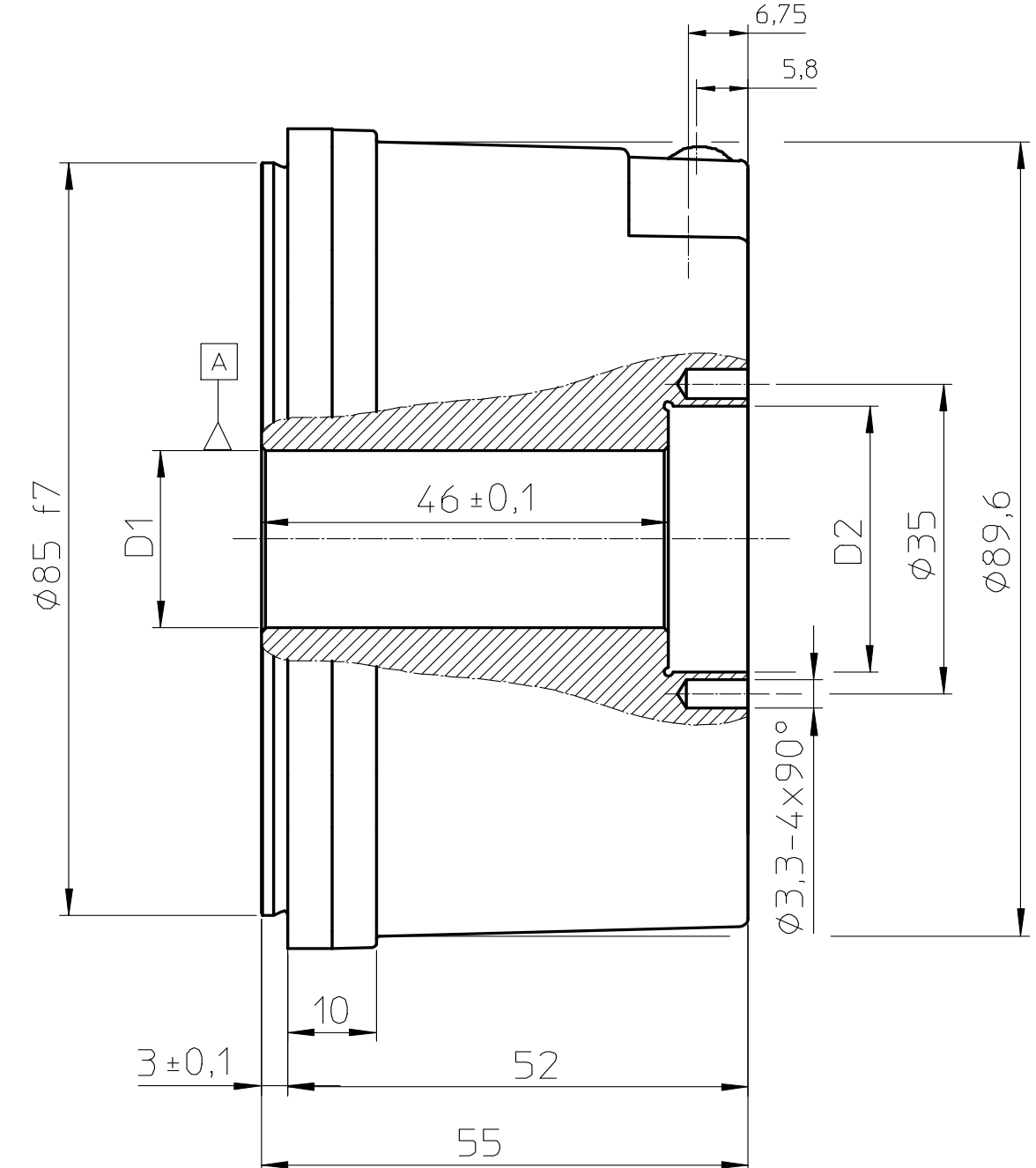
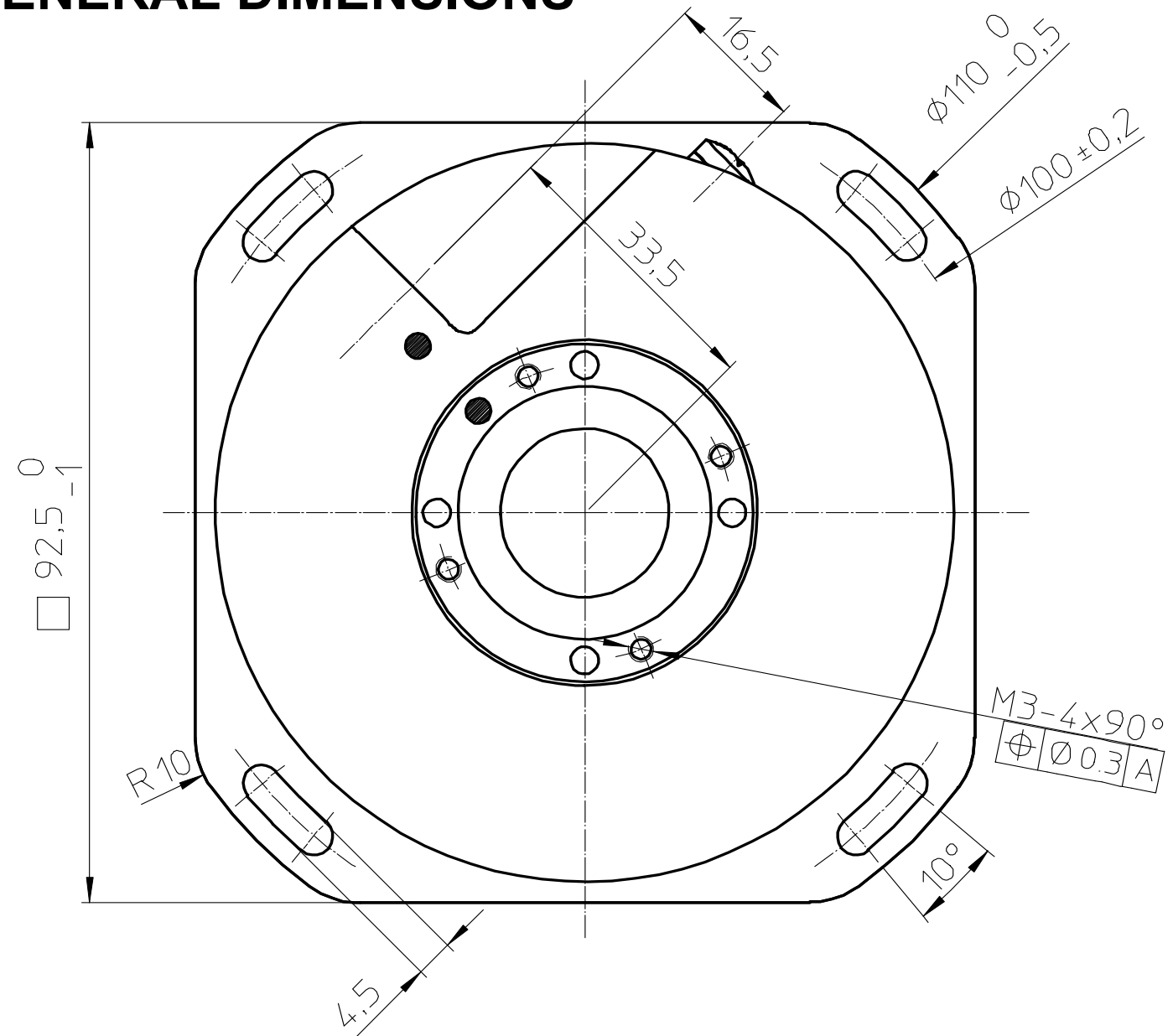

Precisión Accuracy	$\pm 2.5''$	$\pm 5''$
D1	$\phi 20 H6$	$\phi 20 H7$
D2	$\phi 30 H6$	$\phi 30 H7$

MONTAJE / MOUNTING

Cotas de montaje / Mounting dimensions

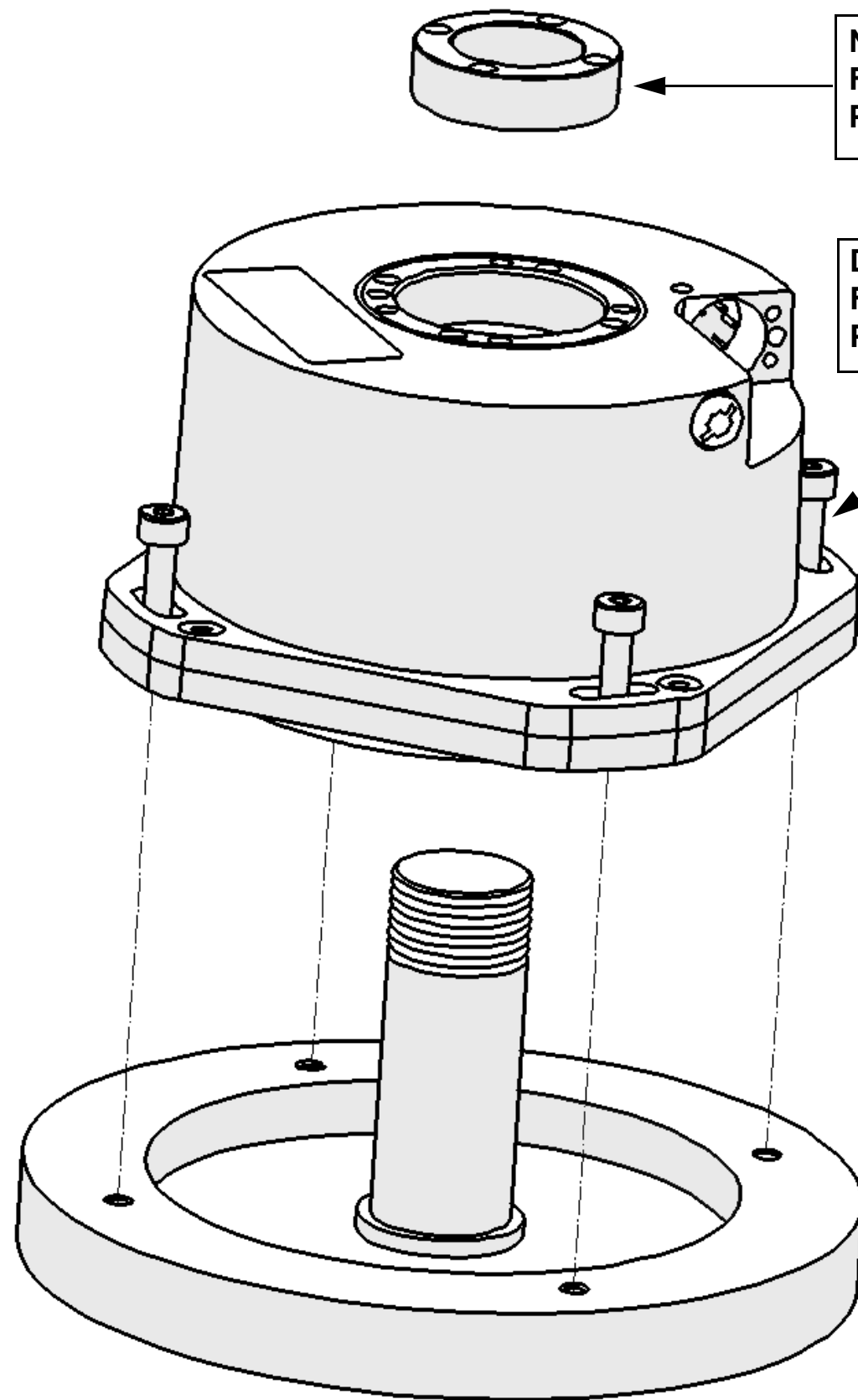

Nut / Tuerca Ref. T-20
Fastening torque = 20 Nm
Par de apriete = 20 Nm

DIN 912 - M4x16
Fastening torque = 2.5 Nm
Par de apriete = 2.5 Nm

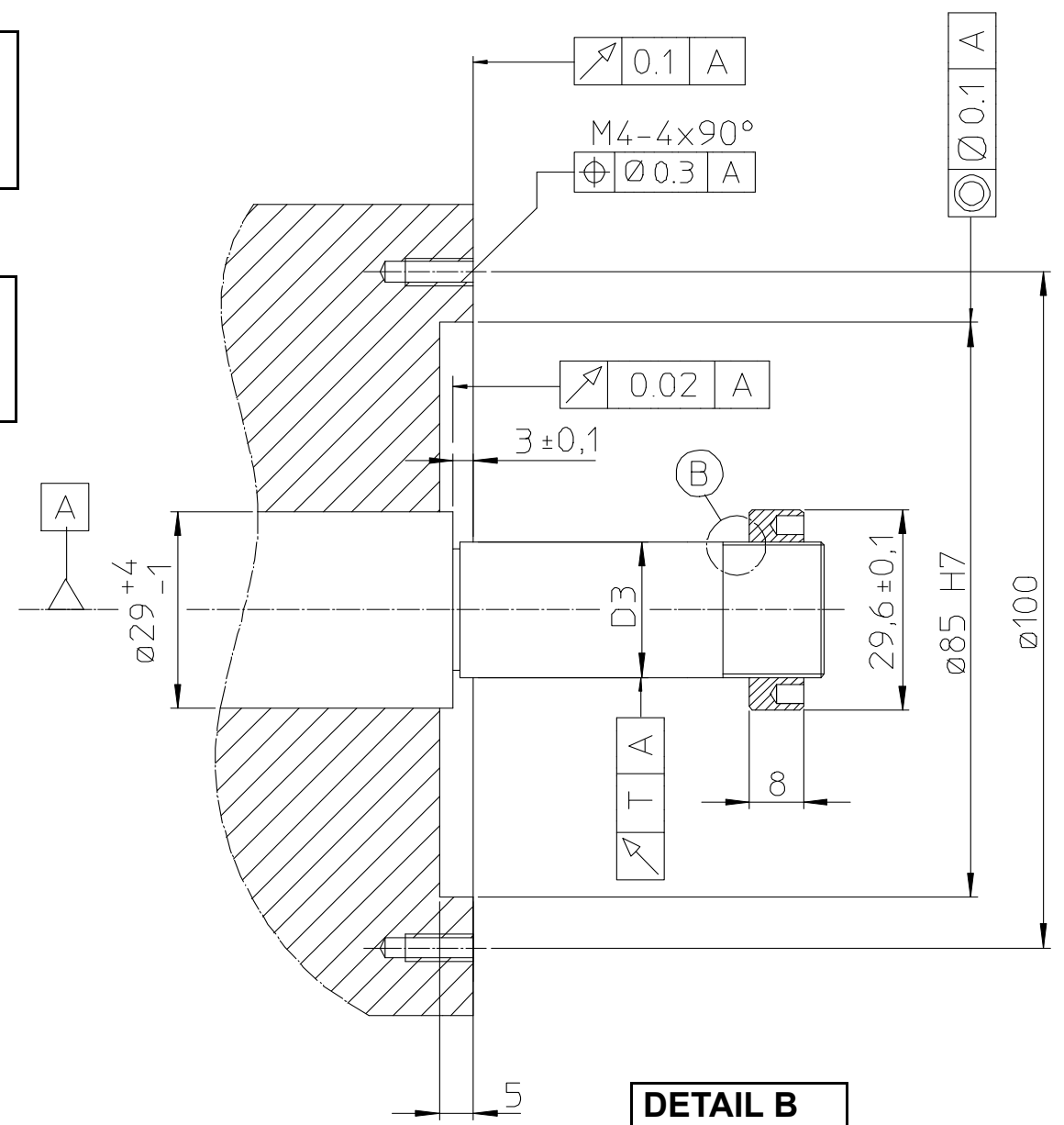

DETAIL B
DETALLE B

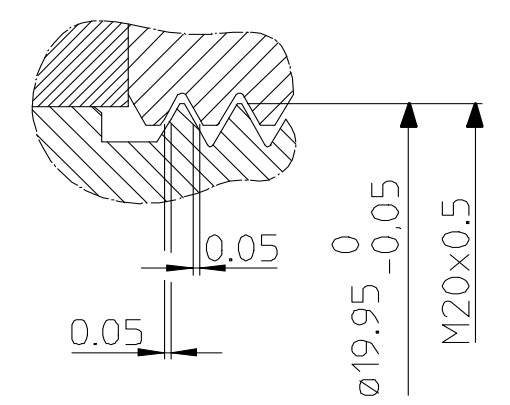

Precisión / Accuracy	$\pm 2.5''$	$\pm 5''$
D3	$\varnothing 20 \text{ g6}$	$\varnothing 20 \text{ g7}$
T	0.01	0.02

A Rodamiento / Roller bearing

MONTAJE / MOUNTING

Cotas de montaje / Mounting dimensions

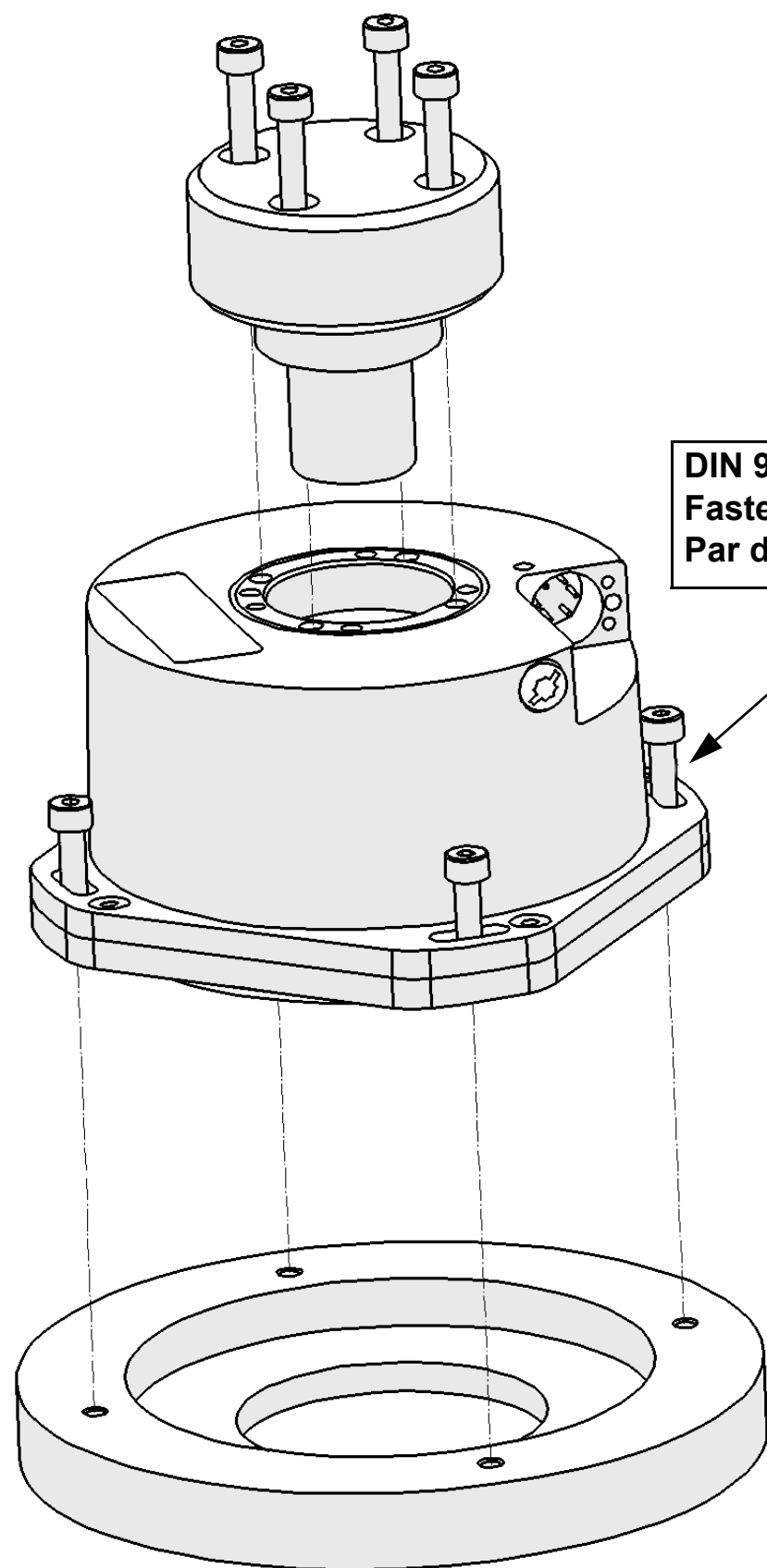

DIN 912 - M4x16
Fastening torque = 2.5 Nm
Par de apriete = 2.5 Nm

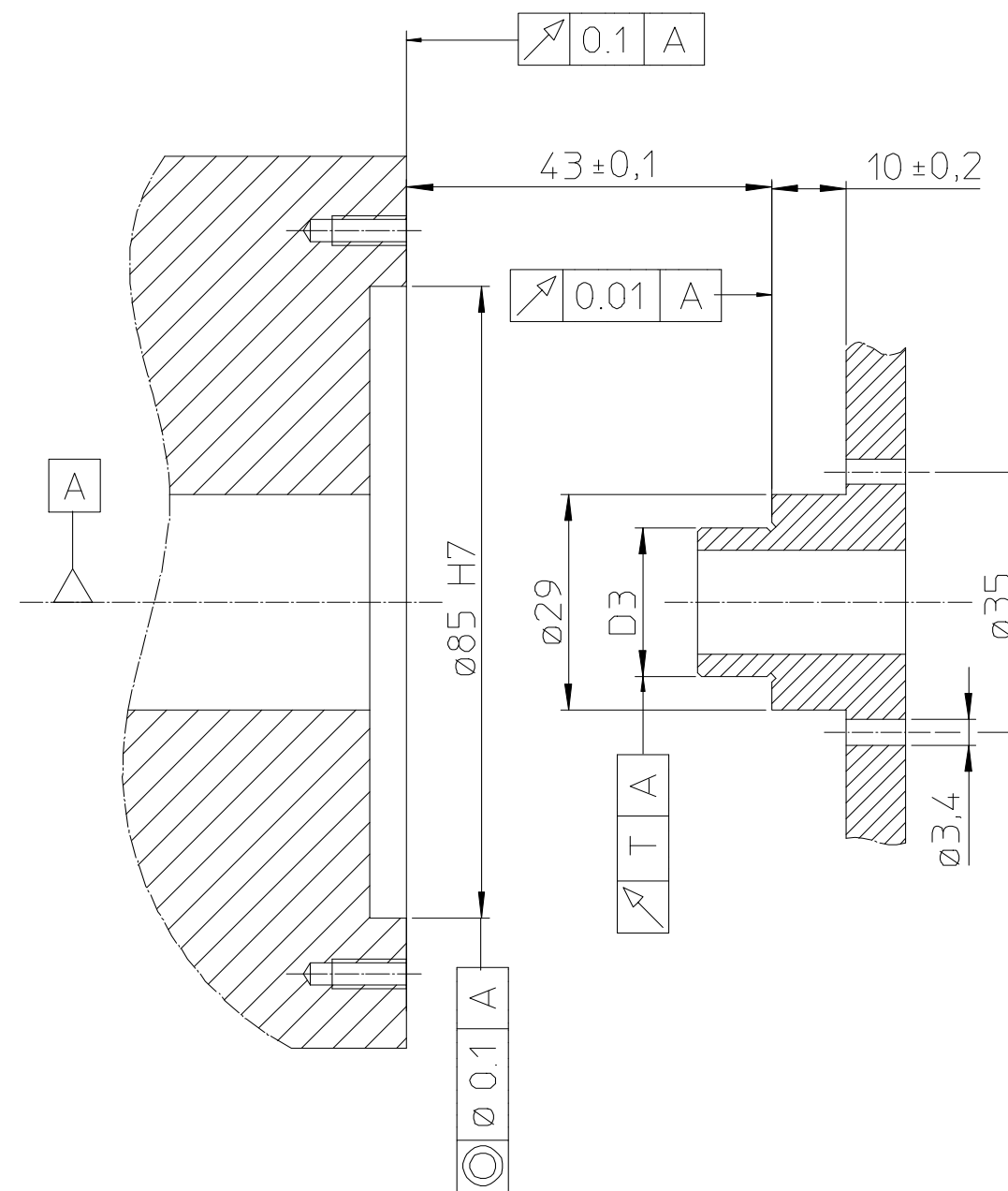

Precisión Accuracy	±2.5"	±5"
D3	∅20 g6	∅20 g7
T	0.01	0.02

A Rodamiento / Roller bearing

TUERCA T-20 / T-20 NUT

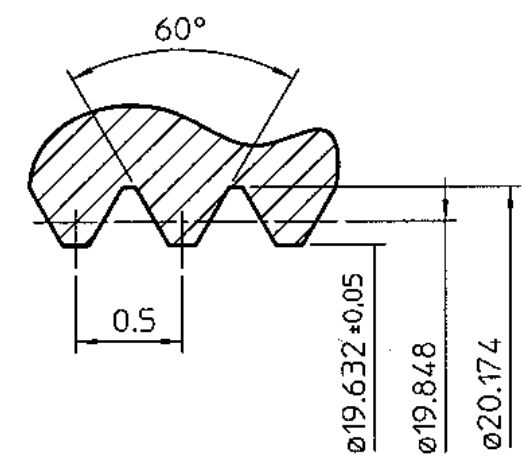
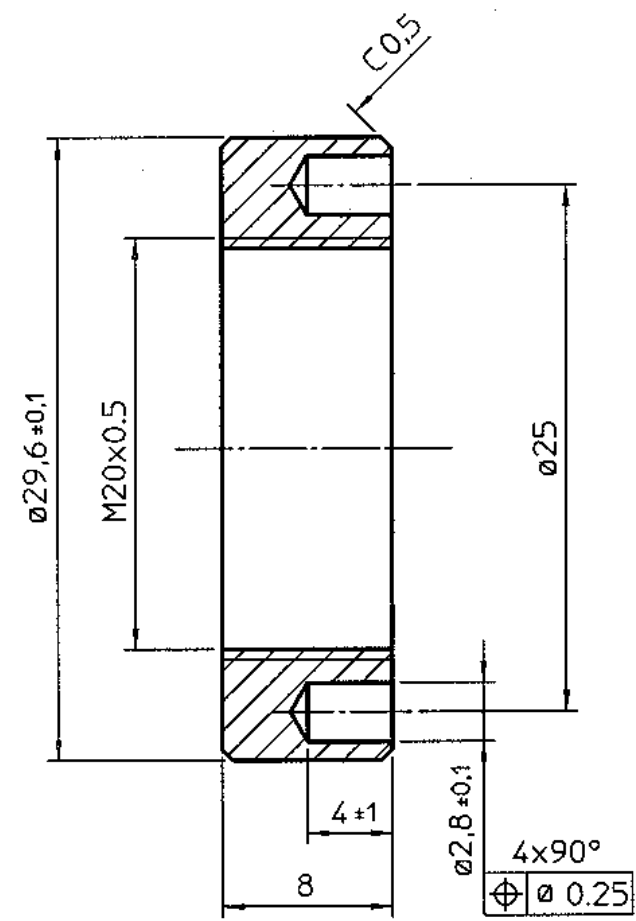
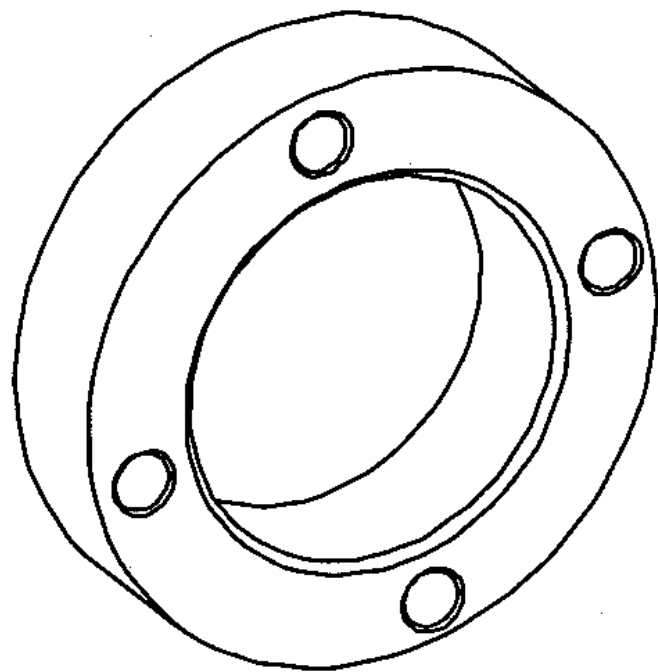

Nivel máximo: IP 64
Maximum level IP 64

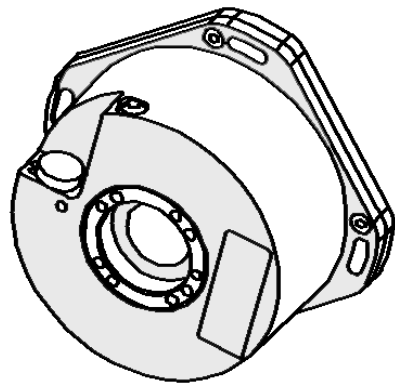

> IP 64

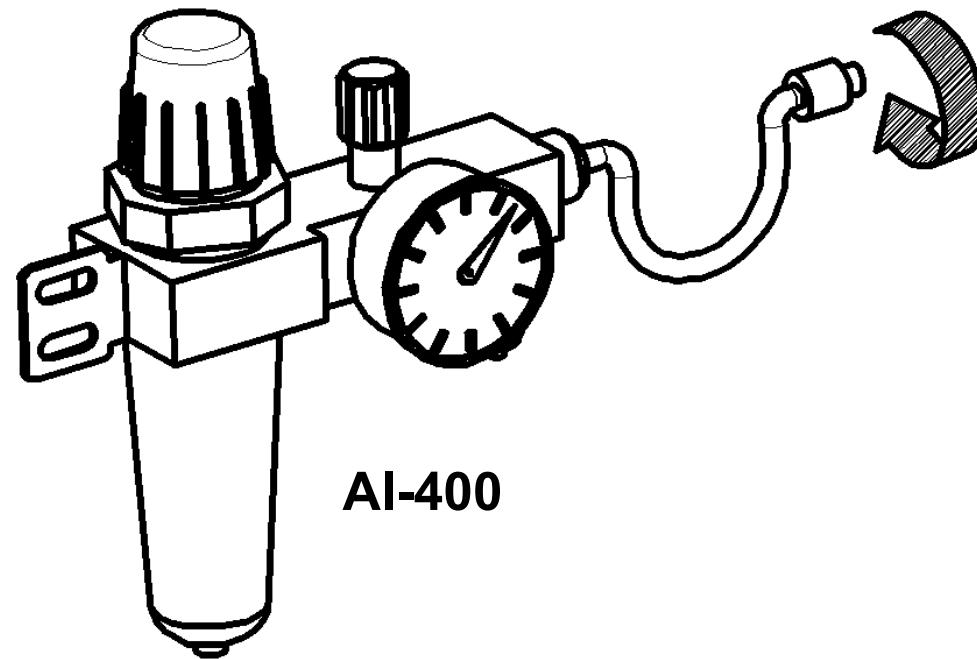

AI-400

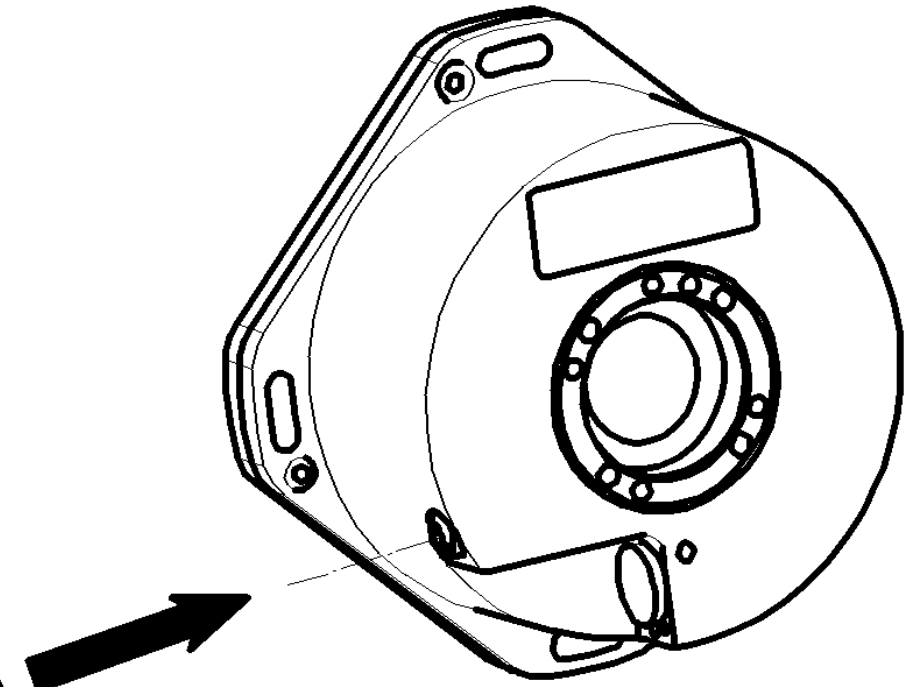

(A) AIR CONDITIONS	
DIN ISO 8573 -1	
Class 1 - Particule Max. 0.1 μ	
Class 4 (7 bar) - Punto rocío / dewpoint 3 °C	
Class 1 - Max. Concentration oil 0.01 mg/m ³	
Presión / Pressure	1 Kg / cm ³
Flujo / Flow	10 l. / min. / encoder

AI 590

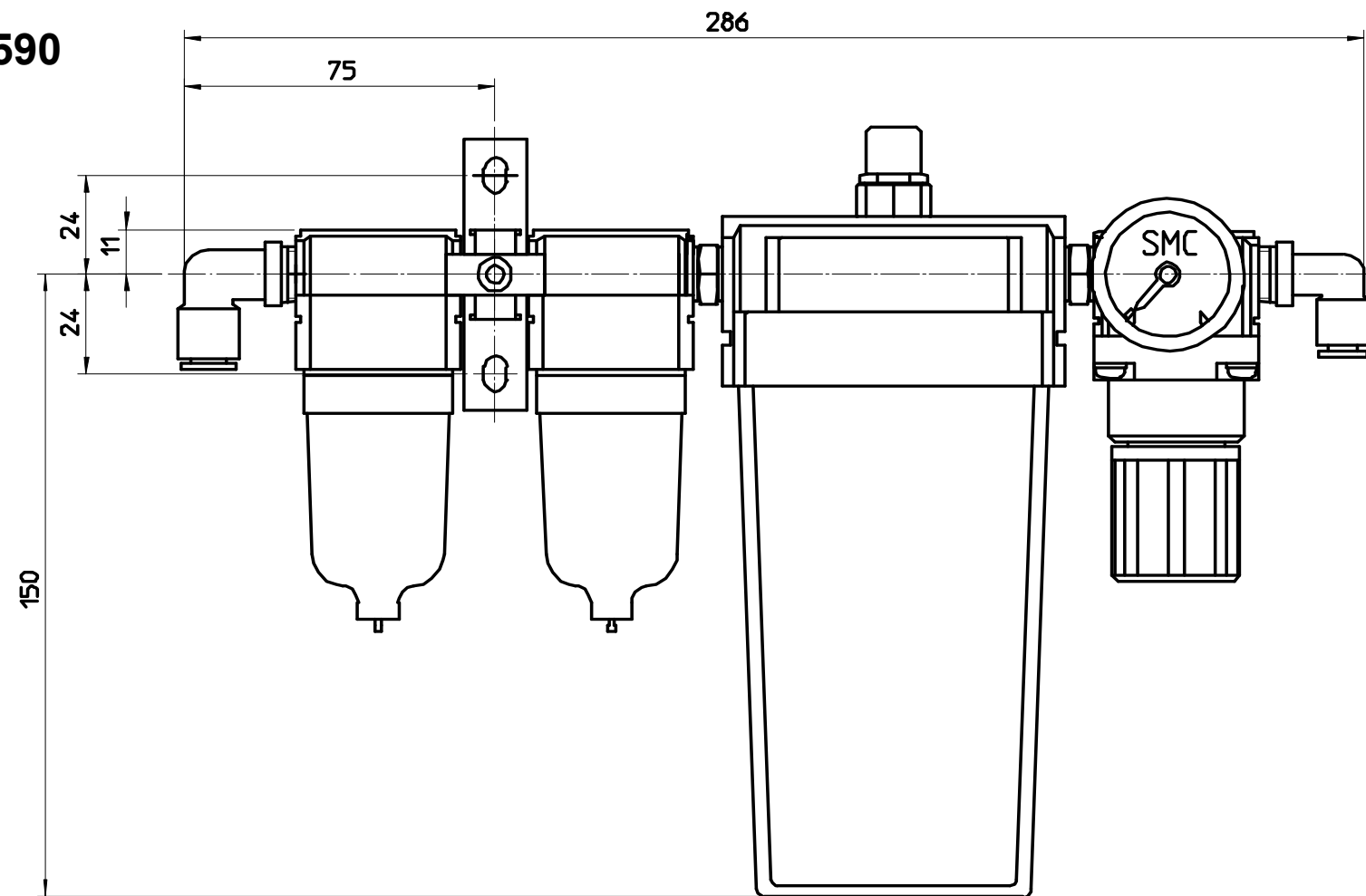

FILTROS DE AIRE / AIR FILTERS

2200000	AI 400	25 l/min
2200001	AI 525	25 l/min
2200002	AI 550	50 l/min
2200003	AI 590	90 l/min

AI 525 / AI 550

AI 400

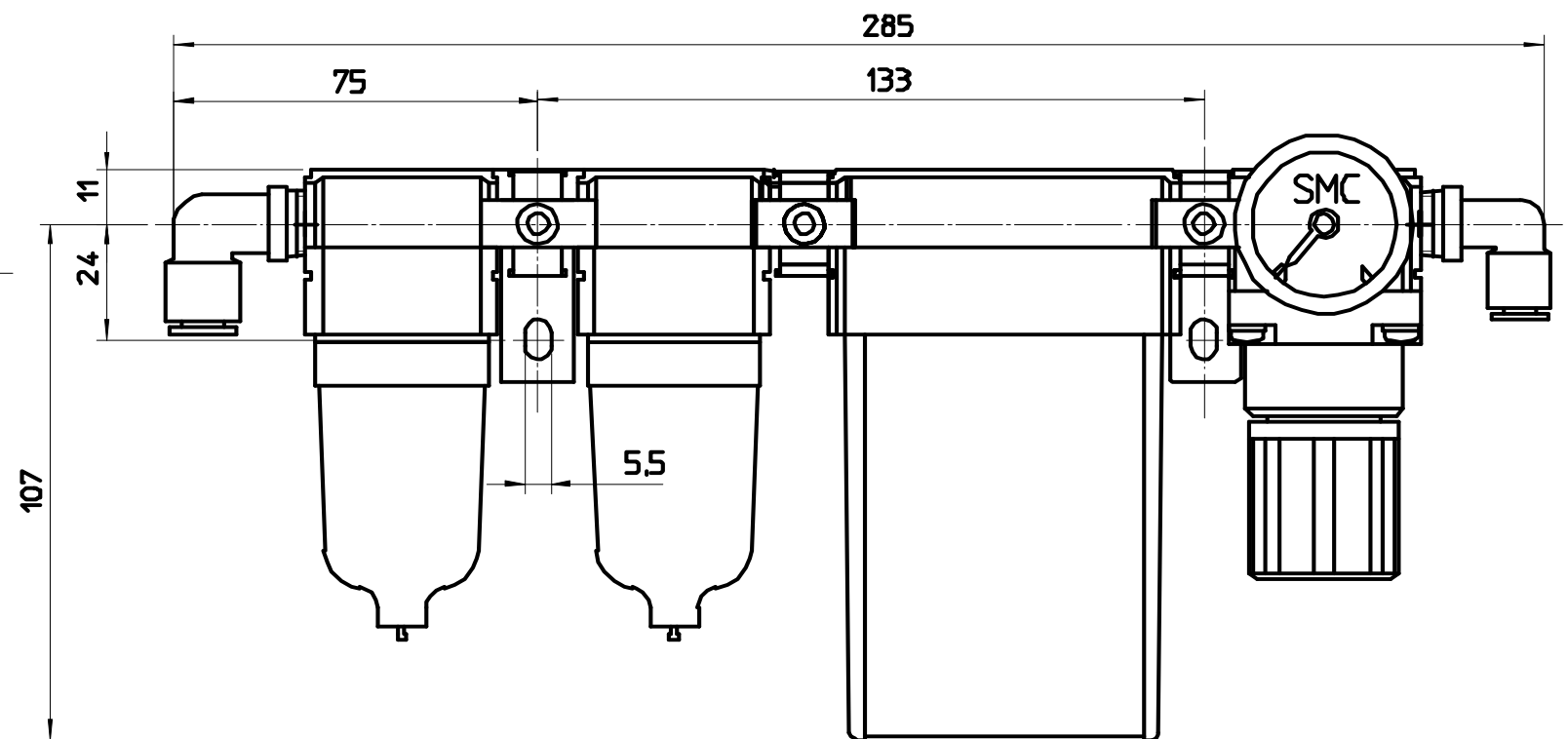
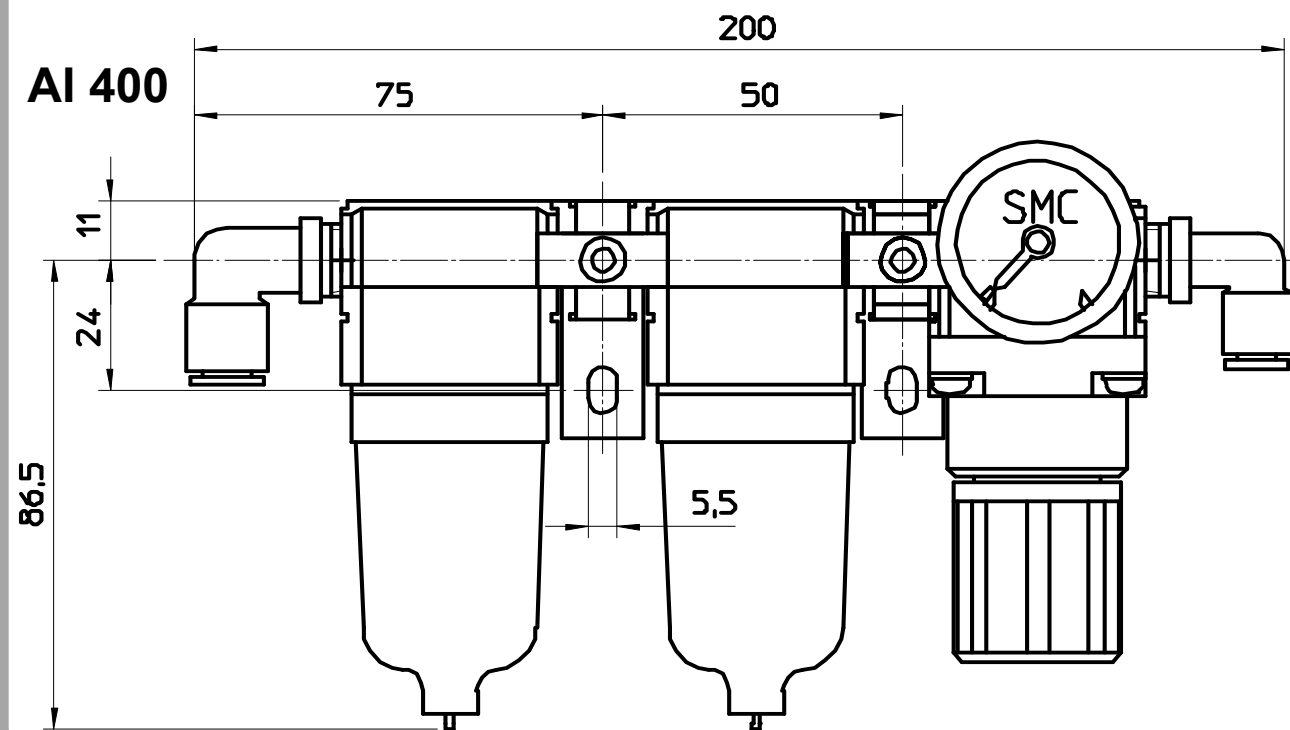

CARACTERÍSTICAS MECÁNICAS MECHANICAL CHARACTERISTICS

Modelo	HAD-D90-27	HAD-D90-23	Model
Precisión	±2.5"	±5"	Accuracy
Maxima velocidad de giro	3000 rpm *		Max. Turning speed
Momento de inercia del eje	650 gr.cm ²		Inertia of the rotor
Par (20°C)	< 0.08 Nm		Torque
Frecuencia natural	> 1000 Hz		Natural frequency
Peso	0.9 kg		Weight
Estanqueidad	IP-64 (DIN 40050)		Sealing protection
Vibración (50-2000 Hz)	100 m/sec ² (IEC 68-2-6)		Vibration (50-2000 Hz)
Impacto (6 ms)	1000 m/sec ² (IEC-68-2-27)		Impact (6 ms)
Temperatura de almacenamiento	-30 °C ... 80 °C (-22 °F ... 176 °F)		Storage temperature
Temperatura de funcionamiento	0 °C ... 50 °C (32 °F ... 122 °F)	-20 °C ... 70 °C (-4 °F ... 158 °F)	Operating temperature

* Limitación eléctrica = 1500 rpm / *Electrical limitation = 1500 rpm*

CARACTERÍSTICAS ELÉCTRICAS / ELECTRICAL CHARACTERISTICS

	HAD-27-D90-2	HAD-23-D90
Resolución <i>Resolution</i>	27 bit (134 217 728) Pulsos / vuelta <i>pulses / turn</i>	23 bit (8 388 608) Pulsos / vuelta <i>pulses / turn</i>
Alimentación <i>Power supply</i>	3.6 V ... 5.25 V, <300 mA	
Conexión <i>Connection</i>	Con conector incorporado <i>With built-in connector</i>	
Longitud de cable <i>Cable length</i>	100 m 300 feet	

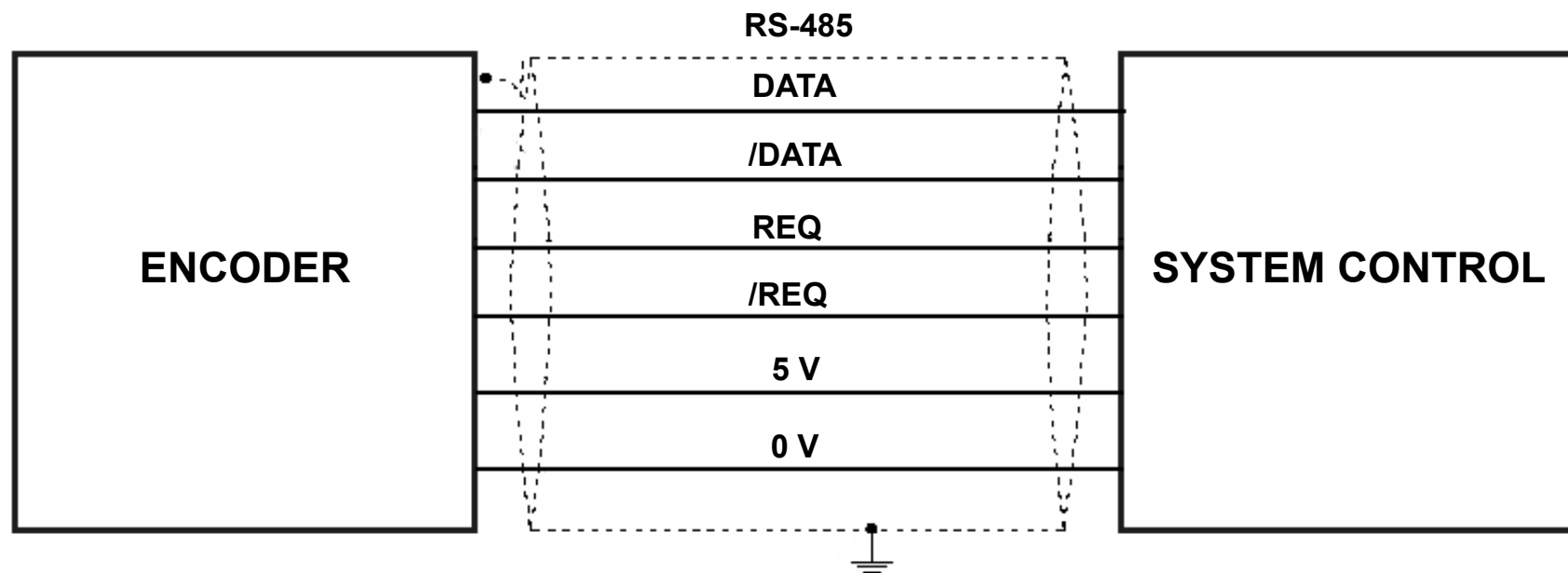

Posición del origen 0°
0° origin position

Girar eje para alinear puntos
Turn the shaft lining up the dots

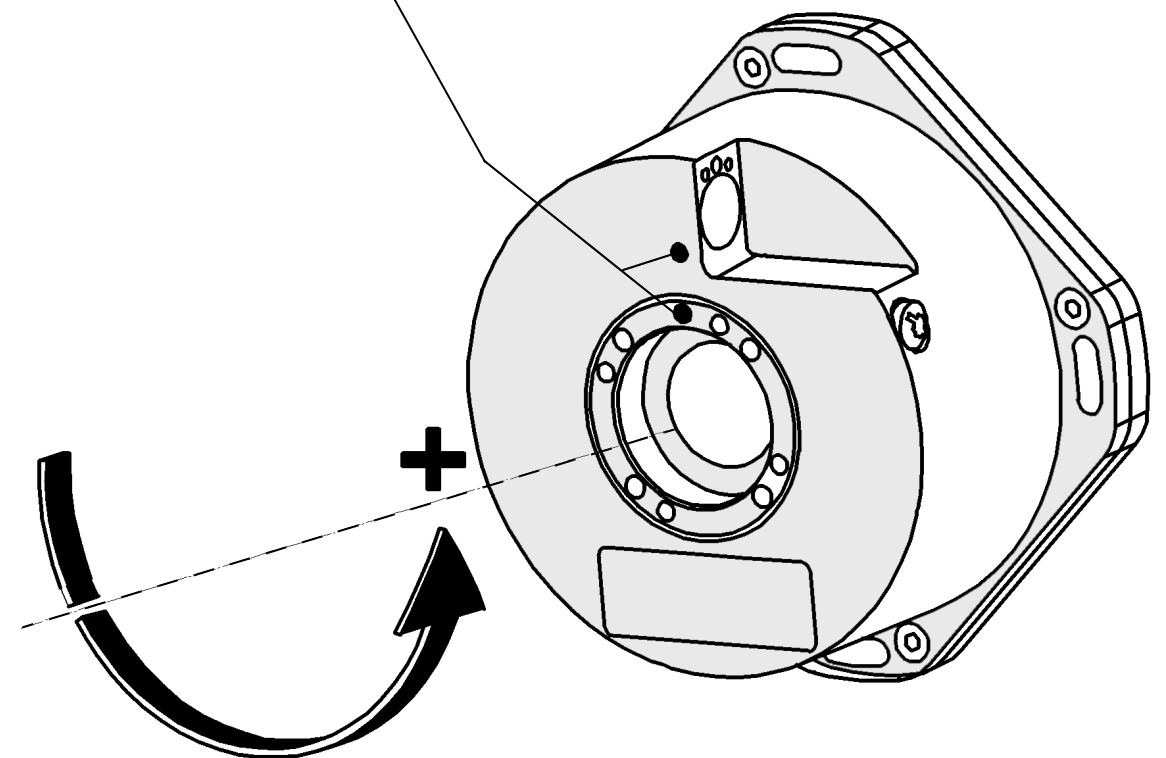

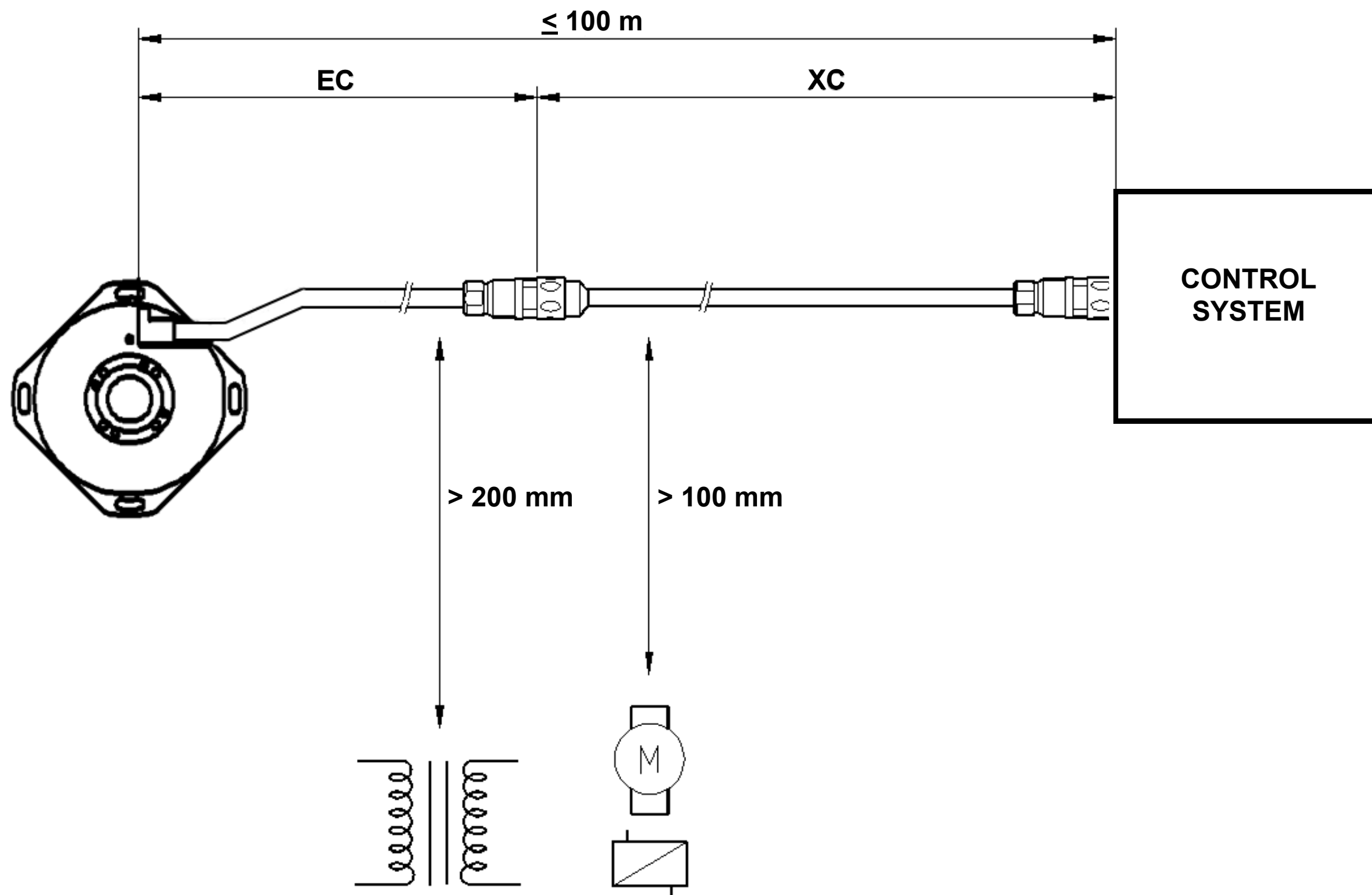

FEEDAT: CONEXIONES / CONNECTIONS

EC-PA-O :

Cable para conexión directa a sistemas absolutos FeeDat full duplex o half-duplex. Disponible en 1, 3, 6 and 9 metros.
Cable for direct connection to full-duplex or half-duplex FeeDat absolute systems. Available in 1, 3, 6 and 9 meters.

SEÑAL SIGNAL	DATA	/DATA	REQ	/REQ	+5V	0V	Tierra / Ground
COLOR	Verde <i>Green</i>	Amarillo <i>Yellow</i>	Azul <i>Blue</i>	Rojo <i>Red</i>	Marrón + gris <i>Brown + grey</i>	Blanco + Rosa <i>White + Pink</i>	Malla <i>Shield</i>

EC...B...C9 Cable disponible en 1 y 3 metros. Contactar con FAGOR para otras longitudes.
Cable available in 1 and 3 meters. Contact FAGOR for other lengths.

Conector (C9) macho circular 17 *male connector*

PIN	14	17	8	9	7	1	10	4	11	Caperuza Housing
SEÑAL SIGNAL	DATA	/DATA	REQ	/REQ	+5V	+5V sensor	0V	0V sensor	Tierra Ground	Tierra Ground
COLOR	Gris Grey	Rosa Pink	Negro Black	Violeta Purple	Marrón Brown	Verde claro Light green	Blanco White	Naranja Orange	Malla interna Internal shield	Malla externa External shield

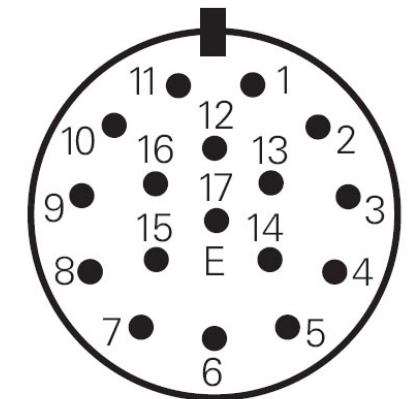

GARANTIA

- *Plazo: 12 meses a partir de la fecha de expedición de fábrica.
- *Cubre gastos de Materiales y Mano de Obra de reparación en FAGOR AUTOMATION.
- *Los gastos de desplazamiento son a cargo del cliente.
- *No cubre averías por causas ajenas a FAGOR AUTOMATION, como: golpes, manipulación por personal no autorizado, etc.

DECLARACION DE CONFORMIDAD

Fabricante: Fagor Automation, S. Coop.
Barrio de San Andrés 19, C.P. 20500, Mondragón -Guipúzcoa- (ESPAÑA)

Declaramos bajo nuestra exclusiva responsabilidad la conformidad del producto al que hace referencia este manual

Nota. Algunos caracteres adicionales pueden seguir a las referencias de los modelos indicados en este manual. Todos ellos cumplen con las siguientes normas:

COMPATIBILIDAD ELECTROMAGNÉTICA:

EN 61000-6-2:2005 Norma de Inmunidad en entornos industriales
EN 61000-6-4:2007 Norma de Emisión en entornos industriales

De acuerdo con las disposiciones de la Directiva Comunitaria: 2004/108/CE de Compatibilidad Electromagnética.

Mondragón a 1 de noviembre de 2012

Fagor Automation, S. Coop.

Director Gerente
Pedro Ruiz de Aguirre

WARRANTY

- *Term: 12 months from factory invoice date.
- *It covers parts and labor at FAGOR AUTOMATION.
- *Travel expenses are payable by the customer.
- *Damages due to causes external to FAGOR AUTOMATION, such as unauthorized handling, blows, etc. are not covered.

DECLARATION OF CONFORMITY

Manufacturer: Fagor Automation, S. Coop.
Barrio de San Andrés 19, C.P. 20500, Mondragón -Guipúzcoa- (SPAIN)

We declare under our exclusive responsibility the conformity of the product referred to in this manual.

Note. Some additional characters may follow the model references indicated in this manual. They all comply with the following regulations:

ELECTROMAGNETIC COMPATIBILITY:

EN 61000-6-2:2005 Standard on immunity in industrial environments
EN 61000-6-4:2007 Standard on emission in industrial environments

According to the European Directive: 2004/108/CE on electromagnetic compatibility.

Mondragón November 1st 2012

NOTAS DE USUARIO / USER NOTES

NOTAS DE USUARIO / USER NOTES

NOTAS DE USUARIO / USER NOTES
